

EFI.05 EARTH FAULT INDICATOR

INSTALLATION MANUAL



JUMPER SETTING

TRIP CURRENT SET

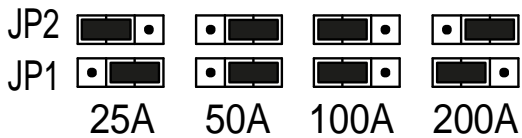

AUTOMATIC TIME RESET

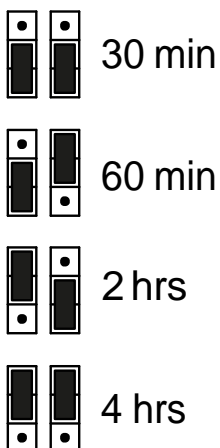

JP6 JP7

FAULT TIME DELAY

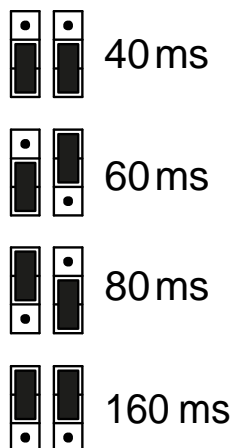

JP4 JP5

4 FIXING HOLES DIAM. 5mm
ON A 63.5mm SQUARE ON
THE BOTTOM OF THE BOX

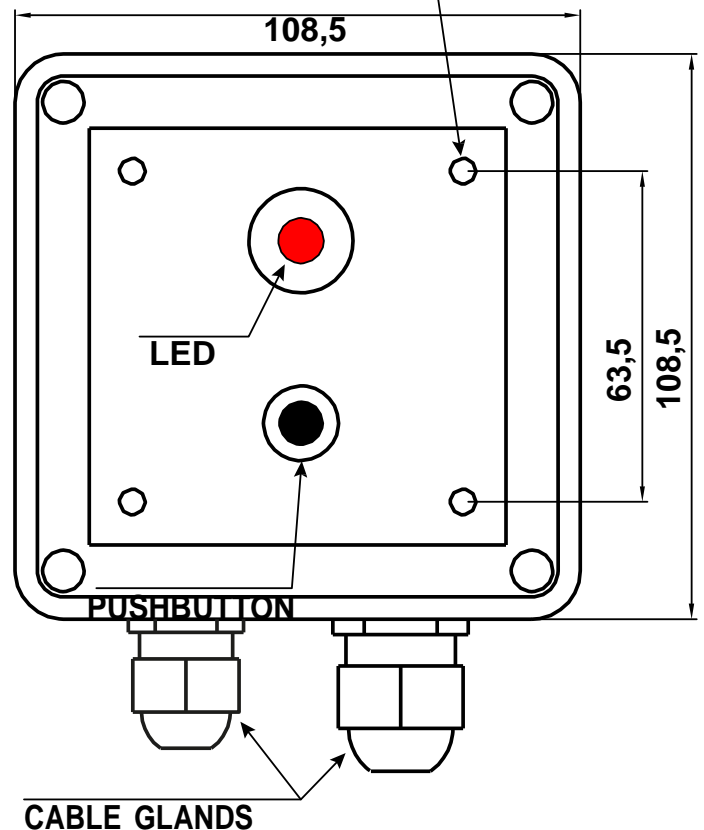

TO OPERATE DEVICE PLEASE REMOVE BATTERY PAPER STRIP

CBCT CURRENT TRANSFORMER INSTALLATION

For packaging reasons the CT might be supplied to you assembled. In this case it is required to simply disassemble the CT before installation.

1. Open the metallic tie completely (photo n. 1). Then make it travel around the MV cable and tie it using few turns of the screw.
2. Place the two halves around the cable, making sure the bottom side has three small teeth and the top side has one small tooth (photo n. 2).



PHOTO n. 1

THE CT SHALL BE INSTALLED OVER THE SHIELDED PART OF THE MV CABLE ACCORDING TO NEXT PAGE DRAWING



PHOTO n. 2

3. Put the metallic tie around the core, tightening until the two halves can just move slightly.

4. Perform the core alignment with fingers, ensuring the two halves match perfectly on the CT height and radially (photos n. 3 and 4).

PAY ATTENTION TO AVOID ANY MISALIGNMENT AS IN PHOTO n. 5.



PHOTO n. 3

5. Now complete the tightening until the two halves cannot move and the core is locked in a firm and secure way (photo n.6 - tightening torque = 2Nm).



PHOTO n. 4



PHOTO n. 5



PHOTO n. 6

6. Place the core with the three teeth close to the cable and fit a plastic tie around the cable and over the three bottom teeth; then fit the second plastic tie around the cable and over the top tooth (photo n. 7).

7. Make now the ties as tight as possible to achieve a firm and secure locking (photo n. 8).

8. Connect the free end of the CT link cable to EFI screw terminals. The cable has no polarity.

9. The link cable must be firmly tied to the pole to avoid the total cable weight pulling down directly from the CT.



PHOTO n. 7



PHOTO n. 8

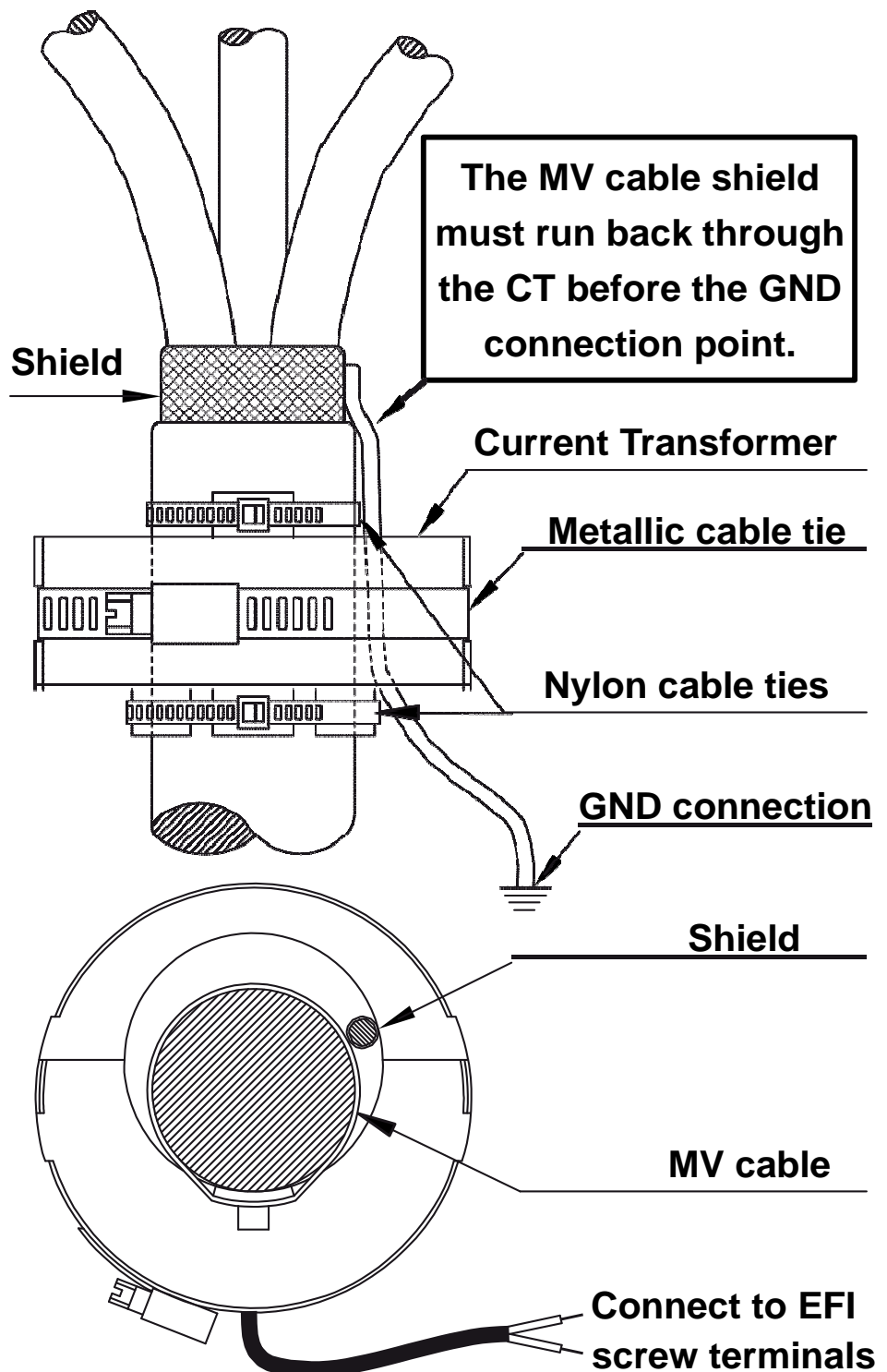

FOR CORRECT OPERATION THE MV CABLE SHIELD MUST RUN BACK THROUGH THE CT BEFORE THE GND CONNECTION POINT (see drawing)

EFI INSTALLATION

1. Install the EFI indicator according to the drawing on front page.
2. Connect the link cables via the cable gland to EFI screw terminals, according to wiring diagram below. Only CBCT current transformer connection is mandatory, other connections are optional (please note that not all the EFI.05 devices have the optional screw terminals for the external indicator).
3. Set the jumpers to the desired operating parameters.

Device test can be performed pressing the test/reset pushbutton on the front.

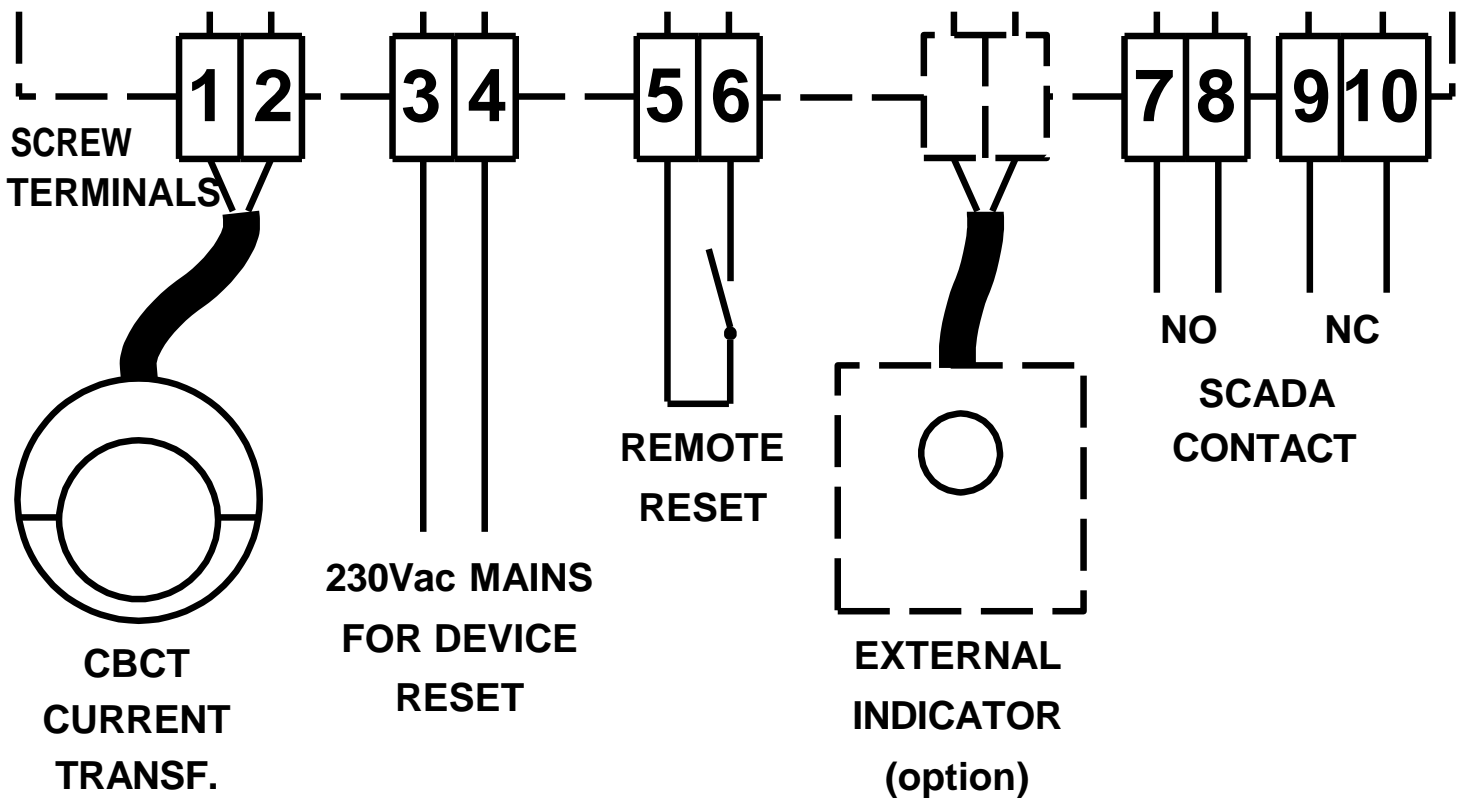

IMPORTANT: TO OPERATE DEVICE PLEASE REMOVE BATTERY PAPER STRIP

We reserve the right to change the design and specification of any item shown herein, therefore the contents shall not form part of any contract or constitute a warranty.